Memo Cover Sheet

LWA FEE Measurements – 01
(LWA Memo #231)

FEE S-Parameter Measurement Procedures with FEE Test Fixture V2

27 May 2026

Whitham D. Reeve

FEE S-Parameter Measurement Procedures with FEE Test Fixture V2

0. General:

- a. These procedures describe FEE S-Parameter measurements using the Copper Mountain Technologies S5045 VNA, custom Calibration Fixtures and a commercial mechanical Calibration Kit, and custom FEE Test Fixture version 2. A block diagram of the FEE Test Fixture is in section 1.
 - b. These procedures also may be used with the nenuFAR low noise amplifier.
 - c. The custom Calibration Fixtures are used to calibrate the VNA Port 1. The hybrid coupler on the FEE Test Fixture Coupler PCB is de-embedded during VNA calibration by using the custom Calibration Fixtures and associated Data-Base Standards.
 - 1) The Calibration Fixtures are version 2 with the MCL AMT-32+ 180° hybrid coupler. These hybrid couplers are identical to the hybrid coupler on the Coupler PCB in the upper bay of the FEE Test Fixture V2.
 - 2) Two Calibration Fixtures are used, one for calibrating the A-side and one for calibrating the B-side prior to measuring the A- and B-sides of the FEE. The only difference in the A- and B-sides of the calibration fixtures is the direction of the RF connector on the PCB. The Calibration Fixture A- and B-side PCBs are sandwiched together in the same manner as the FEE A- and B- side PCBs.
 - 3) The custom Calibration Fixtures are defined in the VNA software using Data-Based Calibration Standards produced from previous S-Parameter measurements after the VNA and associated test cables had been calibrated with an Automatic Calibration Module.
 - d. The commercial Calibration Kit is used to calibrate the VNA Port 2. The bias-tee and associated cables in the lower bay of the FEE Test Fixture V2 are de-embedded during calibration using the commercial Calibration Kit and two short proxy cables. The proxy cables are identical to those used in the FEE Test Fixture V2 lower bay. Disassembling the FEE Test Fixture is avoided by using proxy cables.
 - e. Dual assembly FEEs are mounted using all four studs (feedpoints) in the FEE Test Fixture, but only one side is measured at a time. For reference, FEE Side A = Side facing up and FEE Side B = Side facing down when mounted in the Test Fixture.
 - f. The measurement frequency range is 2 to 200 MHz.
-

FEE S-Parameter Measurement Procedures with FEE Test Fixture V2

1.1. Preliminary:

- a. The 30 dB attenuator on the FEE Test Fixture RF Input, if equipped, is to be removed and not reconnected until all measurements are completed. This attenuator is used only when a spectrum analyzer with tracking generator is used to measure FEE gain.
- b. Test equipment:
 - 1) FEE Test Fixture V2 (equipped with MCL AMT-32+ on Coupler PCB) , custom built. This test fixture includes one MCL 141-6SMRSM+ Internal Input Jumper Cable and one Bracke 92306.12 (RG-188D) Internal Output Jumper Cable, both cables in the upper bay
 - 2) Calibration Fixtures V2, Open, Short, Load, and Unknown Thru, custom built
 - 3) Calibration Kit, SMA or 3.5 mm Female (see c. below)
 - 4) Copper Mountain Technologies S5045 vector network analyzer (see c. below)
 - 5) Test cables, 1 m long, SMA-M : N-M, MCL ULC-1M-SMNM+, 2 required (marked Red & Green)
 - 6) Jumper Cable, 6 in long, MCL 141-6SMRSM+ (proxy Input Jumper Cable)
 - 7) Jumper Cable, 12 in long, Bracke 92306.12 (RG-188D) (proxy Output Jumper Cable)
 - 8) Coupler, SMA-Female-Female, Bulkhead type (for proxy cables)
 - 9) Torque wrench, 5/16 in (8 mm), Pre-set to 5 in-lbs (0.56 N-m)
- c. Test set status:

Mfr	Type	S/N	Cal due
CMT	Compact S5045 VNA, SW 25.1.2	2337110	TBD
MCL	KSOLT-63-S+ SMA Calibration Kit	2230-007 (Female)	TBD

1.2. S-Parameter Measurements:

- a. These procedures measure all four S-Parameters of the FEE: S11, S21, S12, S22.
 - b. The VNA ports are calibrated using 2-Port SOLT procedures with output power set to 0 dBm. The output power is then reduced to -35 dBm (Port 1) and -25 dBm (Port 2) for subsequent FEE measurements. The Port 1 power level provides an optimum VNA receiver input level (after amplification by the FEE) for S11 measurements and a 16.5 dB margin below the 1 dB output compression level of the FEE.
 - c. To compensate for the reduced dynamic range when the VNA output power is reduced, the IF bandwidth is reduced to 1 kHz (from 10 kHz default) prior to VNA calibration. Moderate sweep averaging also is used to reduce trace noise.
 - d. The S-Parameters are measured for both sides (A & B) of each FEE. This requires recalibrating the VNA and reconnecting the FEE in the FEE Test Fixture for each side. Recalibrations and reconnections are reduced by measuring all Side-As and then all Side-Bs of the FEEs under test.
 - e. The VNA is calibrated at the beginning of each measurement day. It is recalibrated if any of the following are changed after initial calibration: Frequency range; IF Bandwidth; Resolution; and Lab temperature by more than 5 °C. Notes: 1) These procedures do not require changing any of these settings and the lab temperature and humidity are stable; 2) Output power of the CMT VNA can be changed without affecting calibration.
 - f. All FEEs have a serial number indicated in the filename when saving the measurements.
-

FEE S-Parameter Measurement Procedures with FEE Test Fixture V2

1.3. Setup:

a. FEE Test Fixture V2:

- Set FEE Test Fixture switches for Internal Power and turn OFF

b. System setup:

- Preset → OK

c. Stimulus setup:

- Start → 2.0 MHz, Stop → 200.0 MHz
- Points → 1001
- Sweep type → Lin Freq
- IF Bandwidth → 1 kHz
- Power → Port Couple → Off
- Power → Port Power → Port 1 → 0 dBm → Port 2 → 0 dBm

d. Display setup:

- Allocate Channels → x1
- Number of Traces → 4
- Allocate Traces → x1

e. Markers:

- Markers → Add Marker → 5M, 10M, 20M, 40M, 80M, 160M
- Marker Properties → (Defaults except uncheck Active Only)
- Reposition Marker Tables to avoid traces

f. Average setup:

- Averaging → On
- Average Factor → 10 (default)
- Smoothing → Off

g. Connections for analyzer calibration:

- Refer to Diagram 1.3.1 below
- Connect VNA Port 1 to Side A of the FEE Calibration Fixtures through Test Cable 1 and proxy Input Jumper Cable (MCL 141-6SMRSM) and a proxy SMA-Female coupler (Red)
- Connect VNA Port 2 to the FEE Test Fixture RF Output connector through Test Cable 2.
- Temporarily disconnect the 75 mm Interbay Jumper Cable from the FEE Test Fixture RF Output + dc connector and connect to the proxy Output Jumper Cable (Bracke 92306.12) through a proxy SMA-Female coupler (Green)

h. Calibration:

- Select the Red Side A Calibration Kit Combo from the Cal Kit list
- Calibration → Cal Kit → LWA_Red-A_C → Select
- Calibrate → 2-Port SOLT Cal
- Reminder: Average = 10

FEE S-Parameter Measurement Procedures with FEE Test Fixture V2

- Start Calibration, connect the calibration devices to calibrate the VNA ports:
 - Port1 Open (PCB Open Yel A) → Port1 Short (PCB Short Yel A) → Port1 Load (PCB Load Yel A)
 - Port2 Open (Open SMA-F) → Port2 Short (Short SMA-F) → Port2 Load (Load SMA-F)
 - Port1-2 Thru (Back-To-Back)
 - Apply (if necessary)
 - Save/Recall → Save Type → State & Cal
 - Save State → File → Cal_5-200MHz_Date.Time
 - Averaging → Off
 - Remove the proxy Input Jumper Cable from the Test Cable 1 and connect Test Cable 1 to the FEE Test Fixture RF Input
 - Remove the proxy Output Jumper Cable from the 75 mm Interbay Jumper Cable and reconnect the Interbay Jumper Cable to the RF Output + dc connector on the FEE Test Fixture
- i. Reduce Port 1 output power:
- Stimulus → Power → Port Power →
LWA FEE: Port 1 → -35 dBm → Port 2 → -25 dBm
nenuFAR LNA: Port 1 → -25 dBm → Port 2 → -25 dBm
- j. Connections for FEE measurements:
- Check that FEE Test Fixture power is OFF
 - Refer to Diagram 1.3.2 below and connect the FEE side A (B) to the internal RF Output Cable
 - Install the FEE in the FEE Test Fixture using all four studs
- k. Measure FEE as DUT and save data:
- Turn ON FEE Test Fixture power
 - Average Factor → 20 (or as necessary to reduce trace noise)
 - Averaging → On
 - After Averaging completes, Save/Recall → Save Data to Touchstone File → 2 Port (s2p) → Format → dB-Angle
 - Save File → Filename SNxxxx-A(B)_Date.Time.s2p
 - System → Print → Print Color → Color → Invert Image → Print Date & Time → Print to File
 - Save File → Filename SNxxxx-A(B)_Date.Time.png
 - Averaging → Off
 - Turn OFF FEE Test Fixture power and prepare to measure Side A of the next FEE
 - Repeat Side A measurements of all FEEs from beginning of step j.
- l. FEE Side B measurements:
- Calibrate Side B using step h. and i. except select the Red Side B Calibration Kit Combo from the Cal Kit list: Calibration → Cal Kit → LWA_Yel-B_C → Select
 - Repeat Side B measurements of all FEEs from beginning of step j.
-

FEE S-Parameter Measurement Procedures with FEE Test Fixture V2

Diagram 1.3.1 (Analyzer Calibration)

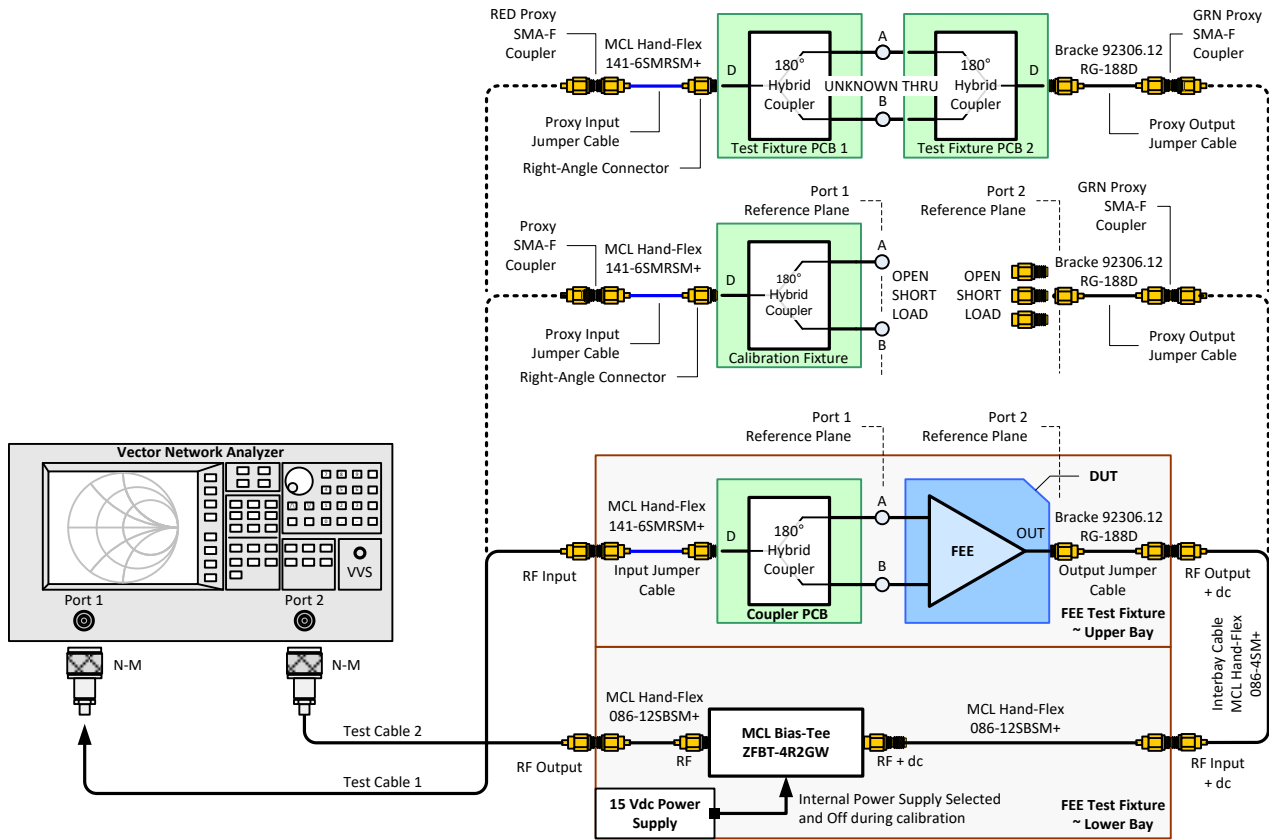
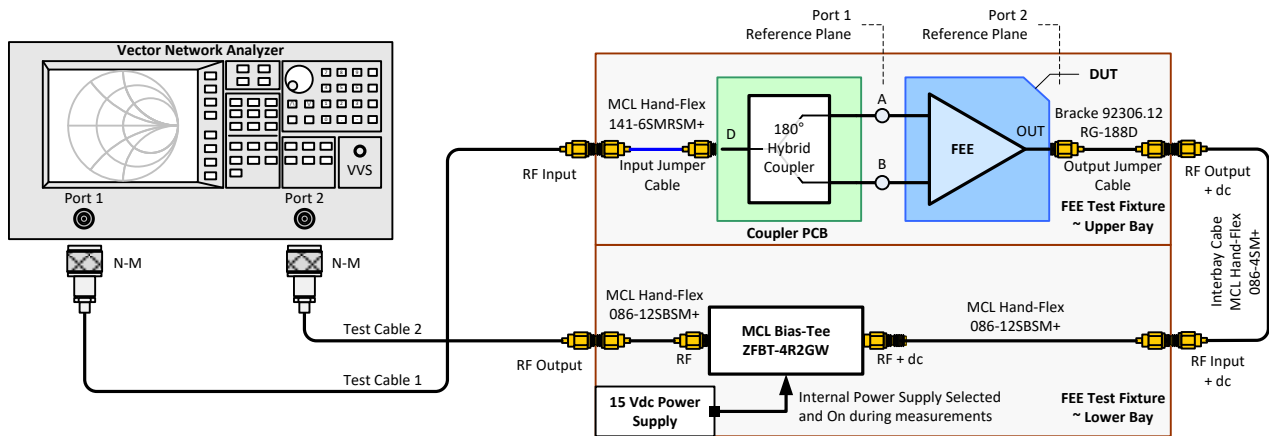

Diagram 1.3.2 (FEE S-Parameter Measurement)



FEE S-Parameter Measurement Procedures with FEE Test Fixture V2

Document Information

Author: Whitham D. Reeve

Revisions: 0.0 (Original draft started based on V1 procedures, 28 Dec 2022)

0.1 (First pass thru procedures, 02 Jan 2023)

0.2 (Revised, 18 Jan 2023)

0.3 (Minor edits, 20 Jan 2023)

0.4 (Calibration revisions based on Zoom call with Brian Walker, Copper Mountain Tech., 23 Feb 2023)

0.5 (Record, 26 Feb 2023)

0.6 (Minor corrections and updates, 20 Feb 2025)

0.7 (Updated for nenuFAR LNA measurements, 27 May 2026)